

## A STUDY ON LINEAR PREDICTION AND WARPED LINEAR PREDICTION CODING OF SPEECH SIGNALS

Rahul Pratap Singh<sup>1</sup>, Professor Chinta Mani Tiwari<sup>2</sup>

<sup>1,2</sup>Department of Mathematics, School of Science, MUIT, Lucknow

### ABSTRACT

*Digital signal processing techniques were first applied to speech processing to simulate complex analog system, Initially, it was viewed that analog systems can be simulated on a computer to avoid the necessity of building the system when digital simulations of analog systems were first applied. The computations required a good deal of time. Today, digital techniques in speech communication system have become vital part of research speech in digital form can be reliably transmitted over very noisy channels. A communication network can be used to transmit both speech and data in digital form. From the point of view of security and secrecy, the digital techniques for speech signal processing are also advantageous. In this paper the application of (+1, -1) system in speech signal processing have been discussed. This system is being employed in linear prediction and warped linear prediction coding of speech signals, power spectral density, prediction gain, correlation function and paracor coefficients have been theoretically analyzed and studied in detail.*

**Keywords-linear prediction & warped prediction coding of speech signals**

### INTRODUCTION

During past three decades, more research has been performed on speech encoding than on any other type of information bearing signal. There are a large number of techniques for telephone quality speech, like PCM, DPCM, DM and ADM. In the range of transmission rate below 9600 bits/sec, all the techniques suffer from wave-form distortion. In this range linear predictive coding is frequently used for speech signal. It provides extremely accurate estimate of the speech parameter and also provides speed of computation. Parametric representation of a spectrum by means of linear prediction is a powerful technique for speech and audio signal processing. Recently linear predictive coding techniques have been studied by many researchers.

In warped signal processing techniques the spectral representation of a system is modified. This is typically done by replacing unit delay element of conventional structure by a first order all pass filters. WLPC utilize the characteristics of human hearing in designing coding algorithm. WLPC techniques have been used by various researchers [1] in speech analysis and coding applications. The comparative study of warped and conventional linear predictive coding has been performed by the author.[2]

Linear predictive coding in (+1, -1) binary system have been studied extensively author.[3] It was found that LPC in (+1, -1) system can be achieved in simple straight forward manner for positive and negative signals in unified way. The binary system (+1, -1) is more efficient than two's complement in conventional binary system in digital signal processing. The main advantage of (+1, -1) system using in speech signal processing is that multiplier cell for filter design which can be constructed for positive and negative signals on a signals on signal chip. Due to cellular circuits, a VLSI design of higher density can be achieved. The cellular array multiplier and carry-save type array multiplier for positive numbers can be realized in (+1,-1) multiplier in a simple and straight forward manner due to unified representation of the bits for positive and negative signals. The details study of digital filter design in (+1, -1) system has been discussed by the author [3] using multiplication and addition processes.

For speech signal processing, conventional two's complement multiplier have been studied by authors [4] for FIR filters, All the authors have used error compensation circuit which is itself a

complex circuit. In this paper our aims to study linear predictive coding and warped linear predictive coding in (+1, -1) binary system. The linear prediction and warped linear prediction have been analyzed by lattice and auto correlation methods to evaluate the prediction gain, parcor-coefficients and power spectral density of speech signal. Parcor-coefficient have analyzed by lattice methods using forward and backward prediction errors at different times. Correlation functions have been computed using the usual Levinson- Durbin algorithm in our system. The effect of adaptive parameter  $\lambda$  on correlation function and prediction gain has been studied in a warped linear prediction coding. The analytical result so obtained in (+1, -1) binary encoding system have been compared with the experimental and other theoretical result and found that this system is well suited for LPC and WLPC.

### SAMPLING, QUANTIZATION AND ENCODING

Following a fractional number in (+1, -1) representation is given by the relation

$$A = \sum_{k=1}^n (a_k) 2^{-k} \dots\dots\dots(1)$$

Where  $(a_k) = +1$  or  $-1$

The digit  $(a_k)$  are bivalued and is related to the conventional digit  $a_k = 0$  or  $1$

The formal relation between  $(a_k)$  and  $a_k$  is given by

$$(\bar{a}_k) = -(a_k) \dots\dots\dots(2)$$

$$(a_k) = 2(a_k) - 1 \dots\dots\dots(3)$$

From equation (1), (2) and (3), we get

$$A = 2 \sum_{k=1}^n a_k 2^{-k} + 2^{-n} - 1$$

$$A = 2A_b + 2^{-n} - 1$$

Where  $A_b$  represents the fraction number represented in a conventional (0, 1) system

In (+1,-1) system, the analog speech signal is sampled to produce a sequence of samples. The sequence of samples is divided into two classes, one for even number of samples and other for odd number of samples; we select only even number of samples. These samples of speech signals are quantized by a uniform quantizer which produces quantized odd samples. The quantized value of sample is encoded by the relation.

$$Q|X| = \sum_{k=1}^n X_k 2^{-k} \dots\dots\dots(4)$$

Where  $(X_k) = +1$  or  $-1$ ,  $X$  is analog value. The quantizer output takes  $2^n$  values equally spaced in the range  $(-1 - 2^{-n}, +1 - 2^{-n})$  for all combination of  $(X_k)$ . The quantizer characteristics for  $n = 4$  is shown in figure 1. The quantizer is symmetric with respect to zero. The representation of analog zero is not possible. The quantization of positive and negative analog values is possible in simple and unified way. The 2's complement quantizer is asymmetric and requires extra bit for sign. The truncation and rounding of quantizer are different in 2's complement rounding is preferred. In our system truncation and rounding are the same. So truncation is used in quantization which is easy to implement.

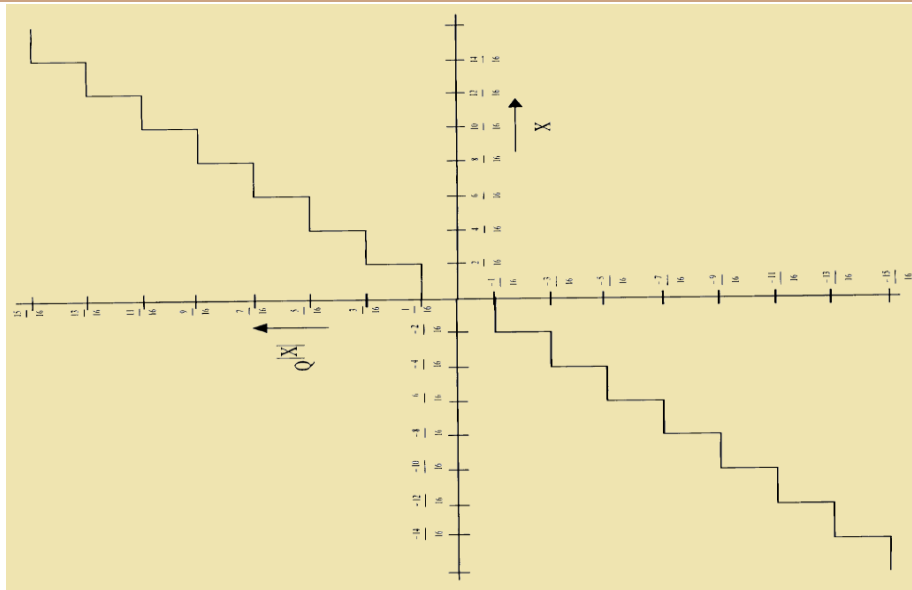

Fig. 1 Four bit quantizer in (+1, -1) system

**AUTO CORRELATION AND FILTERS**

Following the method auto correlation function in our system can be realized for quantized samples 1/8, 3/8, 5/8, 7/8, -1/8, -3/8, -5/8 and -7/8 from 3 bit quantizer. Auto correlation function  $\phi(n)$  of quantized samples is given by the relation.

$$\phi(n) = \frac{1}{N} \sum_{i=1}^{N-n} x_i x_{i+n} \dots \dots \dots (5)$$

where  $n = 0, 1, 2, 3, \dots, p$ ,  $p$  is the order of filter,

Let us take for simplicity three samples as  $x_1 = -1/8, x_2 = +1/8$  and  $x_3 = -3/8$

Now, for  $n = 0$

$$\begin{aligned} \phi(0) &= \frac{1}{3} (x_1 x_1 + x_2 x_2 + x_3 x_3) \\ &= \frac{1}{3} \left( \frac{1}{64} + \frac{1}{64} + \frac{9}{64} \right) \\ &= \frac{1}{3} \left( \frac{11}{64} \right) \\ &= \left( \frac{11}{192} \right) \end{aligned}$$

$$\begin{aligned} \phi(1) &= \frac{1}{3} (x_1 x_2 + x_2 x_3) \\ &= \frac{1}{3} \left( \left( -\frac{1}{64} \right) + \left( -\frac{3}{64} \right) \right) \\ &= \frac{1}{3} \left( -\frac{4}{64} \right) \\ &= \left( \frac{-4}{192} \right) \end{aligned}$$

$$\begin{aligned} \phi(2) &= \frac{1}{3} (x_2 x_3) \\ &= \frac{1}{3} \left( -\frac{3}{64} \right) \\ &= \left( \frac{-3}{192} \right) \end{aligned}$$

First order filter co-efficient is given by

$$a_1 = a_{11} = \frac{\phi(1)}{\phi(0)} = \frac{-4}{11} = -0.363 \dots \dots \dots (6)$$

Hence when it is encoded in (+1, -1) system, it becomes

$$a_1 = 0, (-1) (+1) (-1) (+1) (+1) = 0, \bar{1}1\bar{1}11$$

Second order filter co-efficient is given by

$$a_2 = \frac{\phi(2)\phi(1)}{\phi^2(0) - \phi^2(1)} \dots \dots \dots (7)$$

Substituting the values of  $\phi(0)$ ,  $\phi(1)$  and  $\phi(2)$  we get

$$a_2 = \frac{12}{105} = 0.1142857 = 0, (+1) (-1) (-1) (+1) (+1) (+1) = 0, \bar{1}\bar{1}1111$$

In (0, 1) system the quantized samples for which one bit is for sign are

$$\frac{1}{8}, \frac{2}{8}, \frac{3}{8}, \frac{4}{8}, \frac{5}{8}, \frac{7}{8} \text{ and } -\frac{1}{8}, -\frac{2}{8}, -\frac{3}{8}, -\frac{4}{8}, -\frac{5}{8}, -\frac{7}{8}$$

Here, the three samples are

$$x_1 = -\frac{1}{8}, x_2 = +\frac{1}{8} \text{ and } x_3 = +\frac{2}{8}$$

$$\text{so, } \phi(0) = \frac{6}{192}$$

$$\phi(1) = \frac{-3}{192}$$

$$a_1 = -\frac{3}{6} = .05 = 1.1000$$

$$\phi(2) = \frac{-2}{192}$$

$$a_2 = +0.21 = 0.00111$$

The value of  $\phi(0)$  in (+1, -1) system is large as compared to (0, 1) system but the values of  $\phi(1)$  and  $\phi(2)$  are small. Hence, the 1st order prediction coefficient our case is large in comparison of (0, 1) system. But the second order prediction coefficient is small. The encoding of coefficient in our system have been done using the weights 1/2, 1/4, 1/8 etc as conventional binary for positive number using the bits +1 and -1.

In conventional binary system, the coefficient  $a_1$  is being encoded in two's complement format. Similar is the case for encoding the correlation functions  $\phi(0)$ ,  $\phi(1)$  and  $\phi(2)$ .

First order digital filter is realized by one multiplication and one addition. The difference equation for First order digital filter is given as

$$Y(n) = X(n) + A Y(n-1)$$

The realization filter can be explained through an example,

Let data word length  $m$  and co-efficient word length  $b$  be equal, sat  $m = b = 4$

Here we assume the following numbers

$$X(n) = \frac{-5}{16} = 0.\bar{1}1\bar{1}1$$

$$A Y(n-1) = \frac{5}{128} = 0.1\bar{1}\bar{1}\bar{1}\bar{1}\bar{1}\bar{1}$$

After truncation

$$A Y(n-1) = \frac{1}{16} = 0.1\bar{1}\bar{1}\bar{1}$$

Since two bits addition produces an error, so MSB of truncated bits ( $\bar{1}$ ) is used carry bit. So adding  $X(n)$  with  $AY(n-1)$  with

$$C \text{ in} = \bar{1} \frac{1}{16}$$

We get the value

$$\bar{1}.11\bar{1}1 \ 11\bar{1}$$

So  $Y(n) = 0. \bar{1}1\bar{1}1 = -\frac{5}{16}$ , round off error =  $11\bar{1} = \frac{5}{128}$  Here,  $-\frac{5}{16} + \frac{1}{16} = -\frac{4}{16}$

Cannot be represented in the system. So adding the input carry  $-1/16$ , we get the required result.

The truncated value =  $\bar{1}1\bar{1} = \frac{-3}{128}$

It can be written as  $\frac{-3}{128} = \frac{-1}{16} = \frac{5}{128}$

So, the use of input carry from truncated bit does not introduce any bias error. The rounding error remains the same i.e.  $5/128$ .

In two's complement representation, the number  $X(n) = -5/16 = 1.1011$  where 1st bit is sign bit.

$A Y(n-1) = \frac{5}{128} = 0.0000101$ , 0 is the sign bit. After truncation

$A Y(n-1) = 0.0000$

So,  $Y(n) = X(n) + A Y(n) = 1.1011 + 0.0000 = -5/16$

Which produces the same result as in our system. When rounding is used, the rounded value of  $AY(n-1)$  is given by  $0.000110$  by adding LSB (1) to the actual value of  $AY(n-1) = 0.0000101 = +5/128$ .

The 1st rounded value of  $AY(n-1) = +6/128 = 0.0000110$ .

Using the same process twice, we have the 3rd rounded value of  $AY(n-1)$  and is given by  $0.0001 = +1/16$ .

So,  $Y(n) = 1.1011 + 0.0001$

=  $1.11000$

=  $-4/16$

The rounding error =  $1/6, 5/128 = 3/128$

From the above explanation, it is obvious that the realization of 1st order filter in our system for truncation of rounding is simple as compared to two's complement representation.

In two's complement representation using rounding process, three adders for 3 bits, and extra hardware for two's complement conversion are required. In our cases, such hardware's are not needed. Thus the realization of filter is economical in (+1,-1) system.

The second order filter can be realized by four multiplication and four additions and is given by the expression

$$Y(n) = X(n) + AX(n-1) + BX(n-2) - CY(n-1) - DY(n-2)$$

### First Addition

Let

$$X(n) = -5/16 = 0. \bar{1}1\bar{1}1$$

$$A X(n-1) = 21/128 = 0.1\bar{1}\bar{1}\bar{1}1 \quad \bar{1}1\bar{1}$$

$$|A X(n-1)| = 1/16 = 0.1\bar{1}\bar{1}\bar{1}1$$

$$\text{Addition} = \begin{array}{r} \bar{1}.111\bar{1}1 \\ + \quad \quad \quad \bar{1}1\bar{1} \\ \hline \end{array}$$

So, the result =  $0. \bar{1}1\bar{1}1 = -3/16$

Truncated bits =  $\bar{1}1\bar{1} = -3/128$

Rounding error =  $11\bar{1} = +5/128$

adding carry to rounding error, we get  $-1/16 + 5/128 = -3/128$

### Second Addition

Let

$$BX(n-2) = 25/64 = 0.1\bar{1}\bar{1}11 \quad \bar{1}1$$

$$BX(n-2) = 7/16 = 0.1\bar{1}\bar{1}11$$

$$\text{previous result} = -3/16 = 0.\bar{1}\bar{1}\bar{1}\bar{1}$$

$$\bar{1} \longleftarrow$$

$$\text{Addition} = 1.\bar{1}\bar{1}\bar{1}\bar{1} \quad 11$$

$$\text{So, the result} = 0.1\bar{1}\bar{1}\bar{1} = 3/16$$

$$\text{Truncated bits} = \bar{1}1 = -1/64$$

$$\text{Rounding error} = 3/6$$

**Third Addition**

Let

$$\begin{aligned} \text{CY}(n-1) &= 0.11\bar{1}\bar{1} \quad 11\bar{1} \\ -\text{CY}(n-1) &= 0.\bar{1}\bar{1}11 \quad \bar{1}\bar{1}1 \quad (\text{inversion}) \end{aligned}$$

$$\text{After truncation CY}(n-1) = 0.\bar{1}\bar{1}\bar{1}\bar{1}$$

$$\text{previous result} = -3/16 = 0.1\bar{1}\bar{1}\bar{1}$$

$$\bar{1} \longleftarrow$$

$$\text{Addition} = \bar{1}.11\bar{1}\bar{1} \quad \bar{1}\bar{1}\bar{1}$$

$$\text{So, the result} = 0.\bar{1}\bar{1}\bar{1}\bar{1} = -7/16$$

$$\text{Truncated bits} = \bar{1}\bar{1}1 = -5/128$$

$$\text{Rounding error} = 3/128$$

**Fourth Addition**

Let

$$\begin{aligned} \text{DY}(n-2) &= 0.1\bar{1}\bar{1}\bar{1} \quad 11 \\ -\text{DY}(n-2) &= 0.\bar{1}111 \quad \bar{1}\bar{1} \quad (\text{inversion}) \end{aligned}$$

$$\text{After truncation DY}(n-2) = 0.\bar{1}\bar{1}\bar{1}\bar{1}$$

$$\text{previous result} = -7/16 = 0.\bar{1}\bar{1}\bar{1}\bar{1}$$

$$\bar{1} \longleftarrow$$

$$\text{Addition} = \bar{1}.1\bar{1}\bar{1}\bar{1} \quad \bar{1}\bar{1}$$

$$\text{So, the result} = 0.\bar{1}\bar{1}\bar{1}\bar{1} = -9/16$$

$$\text{Truncated bits} = \bar{1}\bar{1} = -3/64$$

$$\text{Rounding error} = 1/64$$

In this way, 1st and 2nd order filters can be realized in a simple and forward manner for positive and negative numbers together. The realization of higher order filters can be achieved by repeated use of 1st and 2nd order filters.

**WARPED LINEAR PREDICTION**

Following the notation (A. Harma and U.K. Laine et al. 2001), the transfer function of a first order all pass filter is given by

$$D(z) = \frac{z^{-1}-\lambda}{1-\lambda z^{-1}} \dots \dots \dots (8)$$

Where  $\lambda$  is a parameter and is related to sampling frequency  $f_s$ , The frequency at which warping does not effect, the frequency resolution is called turning point frequency and it is given by

$$f_{sp} = \pm \frac{f_s}{2\pi} \text{COS}^{-1}(\lambda) \dots \dots \dots (9)$$

Where  $f_s$  is sampling rate in hertz. For a certain of  $\lambda$ , the frequency mapping shows similarity with the frequency of human auditory system. The parameter  $\lambda$  can be adjust according to best signals for best results, So it is called an adaptive parameter in a coder.

The output of a first order all pass filter  $D(z)$  is given by

$$\hat{X}(z) = [\sum_{k=1}^N a_k D(z)^k] X(z) \dots \dots \dots (10)$$

So

$$\hat{X}(n) = [\sum_{k=1}^N a_k d_k] X(n) \dots \dots \dots (11)$$

Where

$$d_k [X(n)] = h(n) * h(n) * \dots * h(n) * x(n) \dots (12)$$

Where \*sign denotes convolution and  $h(n)$  is the impulse of  $D(z)$

A prediction error filter is given by

$$A(z) = [1 - \sum_{k=1}^N a_k D(z)^K] \dots (13)$$

The synthesis filter is given by

$$A^{-1}(z) = \frac{1}{1 - \sum_{k=1}^N a_k D(z)^K} \dots (14)$$

Therefore, the grain term of  $A(z)$  is given by

$$g = 1 - \sum_{k=1}^N a_k (-\lambda)^K \dots (15)$$

### LATTICE ANALYSIS FOR LPC AND WLPC

Let  $f_m(n)$  and  $b_m(n)$  be the forward and backward prediction errors of the  $m$ th stage lattice filter at times  $n$  respectively. The lattice structure for LPC and WLPC are shown in fig. 2 & 3. For LPC the lattice structure is shown in fig. 2 and for WLPC is shown in fig. 3. The two order recursive equation for LPC and for WLPC are written as;

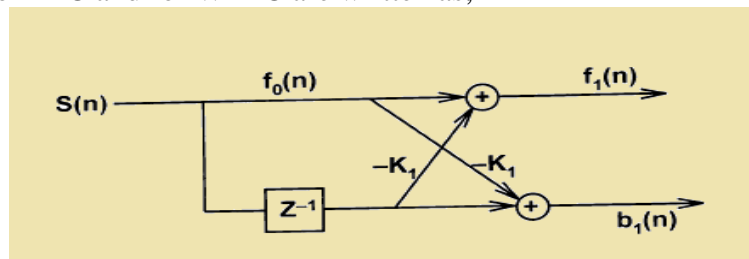

Fig. 2 Lattice structure for LPC

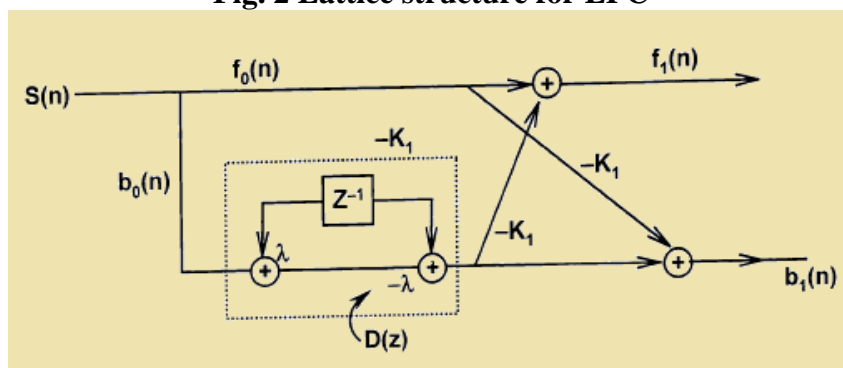

Fig. 3 Lattice structure for WLPC

For LPC

$$f_{m+1}(n) = f_m(n) - k_{m+1} b_m(n-1) \dots (16)$$

And

$$b_{m+1}(n) = b_m(n-1) - k_{m+1} f_m(n) \dots (17)$$

For WLPC

$$f_{m+1}(n) = f_m(n) - k'_{m+1} b_m D(z) \dots (18)$$

and

$$b_{m+1}(n) = b_m D(z) - k'_{m+1} f_m(n) \dots (19)$$

Where  $k_{m+1}$  and  $k'_{m+1}$  are the parcor coefficient in the  $(m+1)$ th lattice stage Forward and backward prediction error autocorrelation function for the  $m$ th stage can be defined as

For autocorrelation

$$\alpha_m^f(t) = \frac{1}{N} \sum_{n=0}^{N-1-t} f_m(n) f_m(n-t) \dots (20)$$

$$\alpha_m^b(t) = \frac{1}{N} \sum_{n=0}^{N-1-t} b_m(n) b_m(n-t) \dots (21)$$

For cross correlation,

$$\beta_m^f(t) = \frac{1}{N} \sum_{n=0}^{n-1} f_m(n) b_m(n-t) \dots \dots \dots (22)$$

$$\beta_m^f(t) = \frac{1}{N} \sum_{n=0}^{n-1} b_m(n) f_m(n-t) \dots \dots \dots (23)$$

Substitute equation (16) and (17) in to (20) and (21), (22) and (23) we get the two recursive equation for LPC

$$\alpha_{m+1}(t) = \alpha_m(t)(1 + k_{m+1}^2) - k_{m+1}[\beta_m(t+1) + \beta_m(t-1)] \dots \dots \dots (24)$$

$$\beta_{m+1}(t) = \beta_m(t+1) - 2k_{m+1}\alpha_m(t) + k_{m+1}^2\beta_m(t-1) \dots \dots \dots (25)$$

Where

$$\alpha_m^f(-t) = \alpha_m^b(t) = \alpha_m(t)$$

$$\beta_m^f(-t) = \beta_m^b(t) = \beta_m(t) \text{ for all } t \text{ and } m$$

For 100 quantized sample like 1/1024, 3/1024, 5/1024....., the correlation function  $\phi(0)$ ,  $\phi(1)$ ,  $\phi(2)$ ,  $\phi(3)$ ,  $\phi(4)$ ,  $\phi(5)$  and  $\phi(6)$  were computed from equation (4.5) and found as 0.0031 785, 0.003082, 0.0029879, 0.0028022, 0.0027625 and 0.0026098 respectively. Thus the autocorrelation function  $\phi(n)$  decreases with increasing n.

Using Levinson- Durbin algorithm, the prediction coefficients  $a_1$ ,  $a_2$  and  $a_3$  were computed and after truncation found as  $a_1 = 0.971$ ,  $a_2 = -0.029$   $a_3 = 0.031$  respectively. The prediction coefficients are encoded in (+1, -1) system for ten bits because about eleven bits are required to provide high quality representation of speech signals with a uniform quantizer and they are given as

$$a_1 = 0.11111\bar{1}\bar{1}\bar{1}\bar{1}\bar{1} \quad (\text{here } \bar{1} = -1)$$

$$a_2 = 0.\bar{1}11111\bar{1}\bar{1}\bar{1}\bar{1}$$

$$a_3 = 0.\bar{1}11111\bar{1}\bar{1}\bar{1}\bar{1}$$

Parcor coefficients  $K_1 = a_{11}$ ,  $K_2 = -a_{22}$  and  $K_3 = -a_{33}$

Let us take the sample

$$x_1 = \frac{-3}{1024} \text{ for } n = 1$$

So,  $f_0(1) = -3/1024$ ,  $b_0(1) = -3/1024$  and  $f_0(0) = -5/1024$

Computing the value of  $\alpha_0(0)$ ,  $\alpha_1(0)$ ,  $\beta_0(0)$ ,  $\beta_1(1)$  using equation (16), (17), (20) and (22), we have

$$\beta_1(1) = 0.00021 = 0.1\bar{1}\bar{1}\bar{1}\bar{1}\bar{1}\bar{1}\bar{1}\bar{1}\bar{1}\bar{1}\bar{1}$$

$$\beta_0(1) = \alpha_1(0) = 0.1\bar{1}\bar{1}\bar{1}\bar{1}\bar{1}\bar{1}\bar{1}\bar{1}\bar{1}\bar{1}\bar{1}$$

Optimal parcor coefficient are given by the relation

$$K_{m+1} = \frac{\beta_m(1)}{\alpha_m(0)} \dots \dots \dots (26)$$

Due to unified representation of positive and negative samples the construction of lattices are cellular and can be integrated on a single chip. Optimal parcor coefficients can be easily achieved by the simple relation (4.26) in which one backward  $\beta(1)$  and one forward  $\alpha(0)$  correlation functions only without going to compute a large expression given by author [5] in conventional binary system. Optimal parcor coefficient are computed from equation (4.26) and found to be

$$K_1 = 0.83 = 0.1\bar{1}\bar{1}\bar{1}\bar{1}\bar{1}\bar{1}\bar{1}\bar{1}$$

$$K_2 = 1.25 = 1.1\bar{1}\bar{1}\bar{1}\bar{1}\bar{1}\bar{1}\bar{1}\bar{1}\bar{1}\bar{1}\bar{1}$$

$$K_3 = 0.97 = 0.1\bar{1}\bar{1}\bar{1}\bar{1}\bar{1}\bar{1}\bar{1}\bar{1}$$

$$K_4 = 0.97 = 0.1\bar{1}\bar{1}\bar{1}\bar{1}\bar{1}\bar{1}\bar{1}\bar{1}$$

For WLPC autocorrelation functions are given by the relation;

$$r(1) = \phi(1) - \lambda\phi(0) - \lambda^2\phi(1) \dots \dots \dots (27)$$

for first order prediction coefficient



$$r(2) = \phi(2)[1 - 4\lambda^2 + 2\lambda^3 - \lambda^4] - 2\phi(1)[\lambda - \lambda^3] + \lambda^2\phi(0) \dots \dots \dots (28)$$

for second order co-efficient and

$$r(3) = \phi(3)[1 - 9\lambda^2 - 9\lambda^4] - \phi(2)[3\lambda - 9\lambda^3 - 3\lambda^5] - \phi(1)[3\lambda^2 + 3\lambda^4] - \lambda^2\phi(0) \dots (29)$$

for third order coefficients.

r(1), r(2) and r (3) have been calculated for different values of  $\lambda$  from eqn. (27), (28) and (29). Parcor coefficients are computed in the similar manner as for WLPC and found as

$$\begin{aligned} K'_1 &= 0.87 = 0.1\bar{1}\bar{1}\bar{1}\bar{1}\bar{1}\bar{1}\bar{1}\bar{1}\bar{1}\bar{1} \\ K'_2 &= 0.35 = 0.\bar{1}\bar{1}\bar{1}\bar{1}\bar{1}\bar{1}\bar{1}\bar{1}\bar{1}\bar{1} \\ K'_3 &= 0.013 = 0.\bar{1}\bar{1}\bar{1}\bar{1}\bar{1}\bar{1}\bar{1}\bar{1}\bar{1} \end{aligned}$$

for WLPC system; the predicted value of signal  $X_n$  is given as

$$X_n = \sum_{k=1}^p a_k(0)x_n D(z)^k \dots \dots \dots (30)$$

Where  $a_1, a_2, \dots, a_p$  are prediction coefficients, substituting the value  $D(z)$  from (8) and using the binomial expansion and solving, we get

$$\begin{aligned} \widehat{X}_n &= \\ &\lambda k \widehat{X}_{n-1} - \frac{\lambda^2 k(k-1)}{2} \widehat{X}_{n-2} + \frac{\lambda^3 k(k-1)(k-2)}{6} \widehat{X}_{n-3} + \dots \dots \dots, -(-1)^k \lambda^k \widehat{X}_{n-k} + \\ &\sum_{k=1}^p q_u X_{n-k} - \sum_{k=1}^p \lambda k a_k X_{n-(k-1)} t + \\ &k=1pk(k-1)2\lambda2akXn-k-2-k=1pkk-1(k-2)6\lambda3akXn-k-3+\dots\dots\dots+k=1p(-1)k\lambda k a \\ &kXn \dots \dots \dots (31) \end{aligned}$$

First modern filter can be realized by the equation

$$\widehat{X}_n = \lambda \widehat{X}_{n-1} + a_1 X_{n-1} - \lambda a_1 \widehat{X}_n \dots \dots \dots (32)$$

For second order filter,

$$\widehat{x}_n = 2\lambda \widehat{x}_{n-1} - \lambda^2 x_{n-2} + a_2 x_{n-2} - a_1 x_{n-1} - \lambda a_1 x_n - \lambda^2 a_2 x_{n-1} + \lambda^2 a_2 x_n \dots \dots \dots (33)$$

The error of sequence is given as

$$e_n = x_n - \widehat{x}_n \dots \dots \dots (34)$$

The mean square error is given as

$$E_p = E(e_n^2) \dots \dots \dots (35)$$

Substituting the value  $e_n$  from (32) and (34) and using equation

$$\sum_{i=1}^p a_i \phi(1 - j) = \phi(j) \dots \dots \dots (36)$$

Where,  $j = 1, 2, \dots, p$

and solving we get

$$E_p = \phi(0) - a_1 \phi(1) + 2\lambda \phi(1) + \lambda a_1 \phi \dots \dots \dots (37)$$

Where nonlinear terms of prediction coefficients are neglected because we are interested in linear terms. The output sequence of the all pole model satisfies the difference equation.

$$x = \sum_{k=1}^p a_k x_n D(z^k) + G V_{in} \dots \dots \dots (38)$$

Where  $G$  is prediction gain and  $V_{in}$  the input sequence,

$$E[G V_{in}]^2 = G^2 E[V_{in}^2]$$

From equation (36),  $E[V_{in}^2] = 1$

For first order filter

$$G^2 = E_p = \phi(0) - a\phi(1) + 2\lambda\phi(1) + \lambda a_1 \phi \dots \dots \dots (39)$$

When  $\lambda = 0$ , it reduces to the gain for LPC

Similarly, for second order filter the predict gain is given by

$$G^2 = \phi(0) - a_1 \phi(1) - a_2 \phi(2) + 2\lambda[2a_1 \phi(1) - 2a_1 \phi(2) + a_1 \phi(0) + a_2 \phi(1)] + 2\lambda^2[a_1 \phi(1) - a_2 \phi(0) + 2\lambda a_2 \phi(1) \dots \dots \dots (40)$$

Where higher order term of  $\lambda$  and nonlinear term of coefficients have been neglected. For  $\lambda = 0$  the equation reduces to second order prediction gain for LPC. Power spectral density of speech signal is determined by double sided Z- transform of auto correlation function.

$$S(z) = \sum_{k=-(N+1)}^{N+1} \phi(K)Z^{-k} \quad \text{for LPC} \dots\dots\dots(41)$$

and

$$S'(z) = \sum_{k=-(N+1)}^{N+1} r(K)Z^{-k} \quad \text{for WLPC} \dots\dots\dots(42)$$

Power spectrum  $S(w)$  is obtained by setting  $Z = \exp(jw)$ , which is as follows

$$S(w) = \sum_{k=-(N+1)}^{N+1} \phi(K)e^{jwk} \quad \text{for LPC} \dots\dots\dots(43)$$

And

$$S'(w) = \sum_{k=-(N+1)}^{N+1} r(K)e^{-jwk} \quad \text{for WLPC} \dots\dots\dots(44)$$

For  $N=100$  samples, power spectrum is shown in figure (4) & (5).

Single stage lattice filter design for LPC and WLPC analysis of speech can be realized as given in figure 4 and figure 5. Lattice structure can be realized by the recursive equation (16) and (17) using forward and backward function of speech signal. The same lattice structure can be realized for WLPC by replacing  $Z^{-1}$  by  $D(z)$  with parcor co-efficient ( $K'$ ).

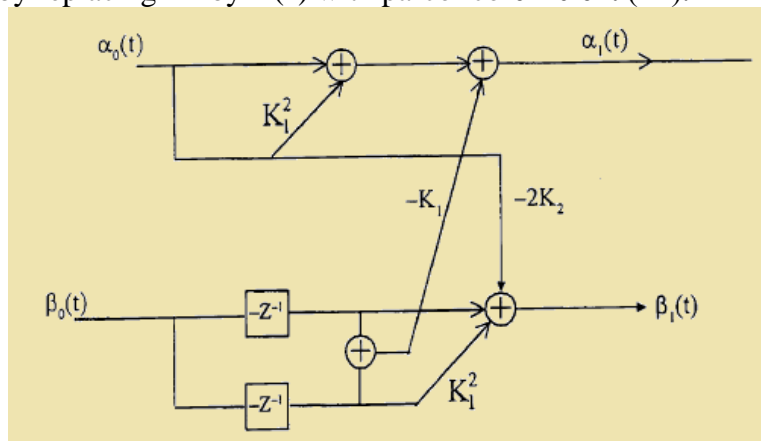

**Fig. 4 Lattice filter design for LPC**

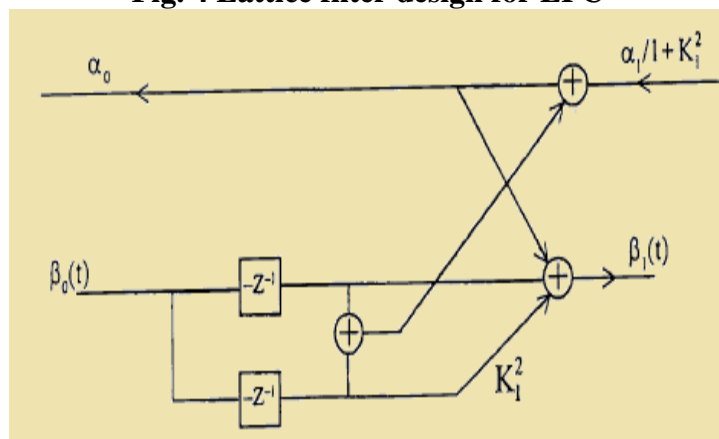

**Fig. 5 Lattice filter design for WLPC**

The block diagram of LPC analysis and synthesis of speech are shown in fig. 6 and fig. 7. The speech signal is sampled and quantized. From the quantized sampled auto- correlation function  $\phi(n)$  for LPC and  $r(n)$  for WLPC are computed. Parcor- coefficients  $K_1, K_2, K_3$  and  $K_1', K_2', K_3'$  for LPC and for WLPC are computed and encoded in (+1, -1) binary system. Auto correlation and cross correlation and backward prediction errors are computed by lattice structure. Pitch is extracted from correlation function voice is detected from speech signal and encoded. The gain parameter is

© 2023 by The Author(s). ISSN: 1307-1637 International journal of economic perspectives is licensed under a Creative Commons Attribution 4.0 International License.

*Corresponding author: Rahul Pratap Singh and Professor Chinta Mani Tiwari Submitted: 27April 2023, Revised: 09 May2023, Accepted: 18 May 2023, Published: June 2023*

determined from auto correlation function and encoded. The encoded parameter is firstly decoded. The gain parameter, parcor- coefficients, V/UV, pitch and excitation goes to the lattice synthesis filter and output of the filter produces the speech signal. The gain parameter is multiplied by V/UV and pitch before applying to synthesis filter. Communicated parameters are given below.

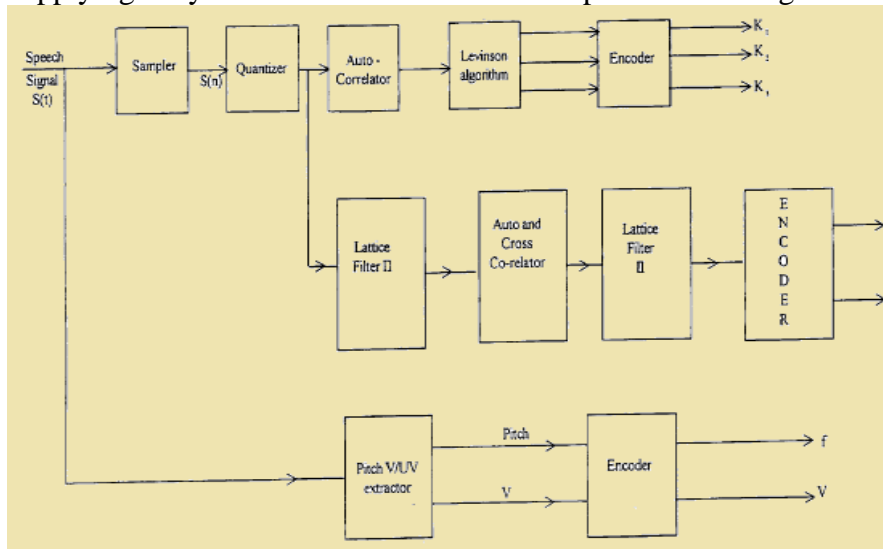

Fig. 6 Block diagram of analysis for LPC

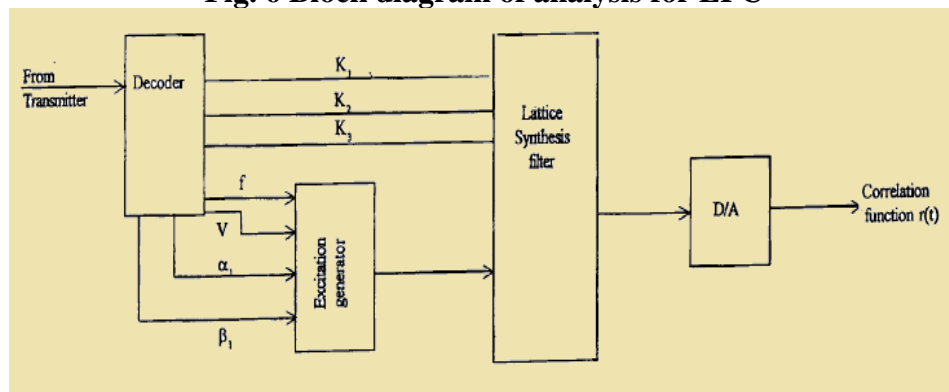

Fig. 7 Block diagram of synthesis for LPC

For LPC

$$K_1 = 0.971 = 0.11111\bar{1}\bar{1}\bar{1}\bar{1}\bar{1}$$

$$K_2 = -0.029 = 0.\bar{1}11111\bar{1}\bar{1}\bar{1}\bar{1}$$

$$K_3 = -0.031 = 0.\bar{1}111111\bar{1}\bar{1}\bar{1}\bar{1}$$

$$G = 0.015 = 0.1\bar{1}\bar{1}\bar{1}\bar{1}\bar{1}$$

For WLPC

$$K_1' = 0.87 = 0.1\bar{1}\bar{1}\bar{1}\bar{1}\bar{1}\bar{1}\bar{1}\bar{1}$$

$$K_2' = 0.35 = 0.\bar{1}11111\bar{1}\bar{1}\bar{1}\bar{1}$$

$$K_3' = 0.013 = 0.\bar{1}111111\bar{1}\bar{1}\bar{1}$$

$$G' = 0.027 = 0.1\bar{1}\bar{1}\bar{1}\bar{1}\bar{1}$$

$$\text{Pitch} = 10 \text{ nesc}, \lambda = 0.1$$

## CONCLUSION

The (+1, -1) binary system can be efficiently applied to processing the speech signals. The unified representation of positive and negative speech signals permit the unified handling of all digits. Digital filters, correlation functions and filter coefficients can be achieved efficiently in

simple and straight manner. Due to cellular circuits for multipliers, adders and sub-tractors, higher density in VLSI realization is possible. Linear prediction coding and warped linear predictive coding can be implemented in simpler form. In general lattice filter realization of linear or warped linear prediction requires the computation of large number of forward and backward and backward error correlations, which in turn requires large space and time. Here, we require only two, one forward and other backward correlation function for a particular time period. One can compute other correlation functions using the lattice. One can easily obtain the correlation step by step. It requires less space and time. In two's complement representation extra hard-wares for sign detection, overflow detection and for conversion process are required. The cellular circuits for all components of LPC and WLPC are possible. The study of prediction gain and correlation function with adaptive parameter is helpful in testing the various speech signals from different speakers.

## REFERENCES

1. J.M. Jou and S.R. Kuang, "Design of Low Order Fixed Width Multiplier in DSP Applications." *Electron. Lett.* Vol.33, pp-1597, 1997.
2. Lan-Da Van et al, "Design of low order fixed width multiplier for speech processing applications," *IEEE Trans, Circuits, Systems*, Vol-44, pp-130, 1999.
3. M. Tiwari, "Linear Predictive coding in a new binary system," *Journal of circuit, systems and computers*, vol. 10, pp-137, 2000
4. Daniel Etiemble, "Comparing quaternary and binary multipliers", arXiv:2005.02678v1 [cs.AR] 6 May 2020
5. Mr. V. Vijaya Narayanan, Ms. S. Gayathri, Mr. F. Arockia Benitto Raj, Mr. K. Ramesh and Mr. R. Maniraj, "LOW POWER ADDER AND MULTIPLIER CIRCUITS DESIGN OPTIMIZATION IN VLSI", *International Research Journal of Engineering and Technology (IRJET)* e-ISSN: 2395-0056 Volume: 07 Issue: 02 | Feb 2020
6. Mohan Shoba and Rangaswamy Nakkeeran, "Energy and area efficient hierarchy multiplier architecture based on Vedic mathematics and GDI logic", [Engineering Science and Technology, an International Journal Volume 20, Issue 1](#), February 2017, Pages 321-331
7. Honglan Jiang, Francisco J. H. Santiago, Mohammad Saeed Ansari, Leibo Liu, Bruce F. Cockburn, Fabrizio Lombardi and Jie Han, "Characterizing Approximate Adders and Multipliers Optimized under Different Design Constraints", May 2019 Pages 393–398 <https://doi.org/10.1145/3299874.3319454>
8. L. Dadda, "On Serial- Input Multipliers for Two's Complement Numbers," *IEEE Trans. on Computers*, vol. 38, pp. 1341-1345, 1989.
9. A.Harma, "Linear Predictive Coding With Modified filter Structures", *IEEE Trans. Speech Audio Processing*, vol. 9, pp. 769,2001.
10. A, Harma, "Implementation of Frequency-Warped Recursive Filter", *Signal Processing*, vol . 80, pp . 543.2000.
11. J. Makhoul, "Stable and Efficient Lattice Method for linear Prediction , " *IEEE Trans. Acoustics, Speech and Signal Proc*; vol. ASSP-25. No. 5 pp. 423-428, October 1977.